



PICO®

**PART # 7256, 7256-6
7257, 7257-6
7258, 7258-6**

Metal Pawl Cable Tie 50lbs Specifications Sheet

OUTLINE DRAWING

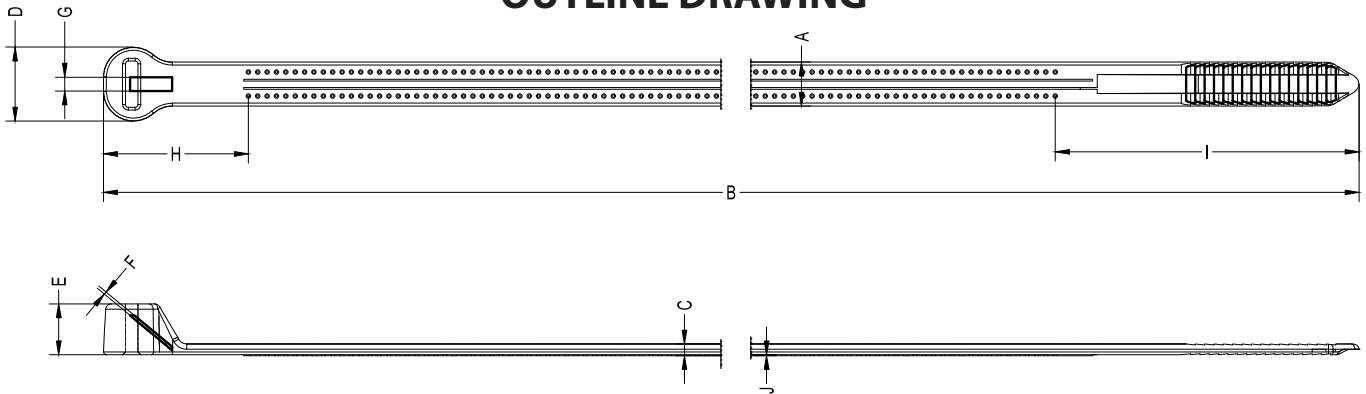

Unit of Measure: mm

NOTES

Part #	Colour	A	B	C	D	E	F	G	H	I	J	Bundle Diameter	
												Min	Max
7256	UV Black	4.8	200	1.25	8.25	5.5	0.3	1.5	15.5	32.5	0.1	3.5	49.5
7256-6	Natural	4.8	200	1.25	8.25	5.5	0.3	1.5	15.5	32.5	0.1	3.5	49.5
7257	UV Black	4.8	300	1.25	8.25	5.5	0.3	1.5	15.5	32.5	0.1	3.5	81
7257-6	Natural	4.8	300	1.25	8.25	5.5	0.3	1.5	15.5	32.5	0.1	3.5	81
7258	UV Black	4.8	370	1.25	8.25	5.5	0.3	1.5	15.5	32.5	0.1	3.5	103.5
7258-6	Natural	4.8	370	1.25	8.25	5.5	0.3	1.5	15.5	32.5	0.1	3.5	103.5

Material (UV Black)	Polyamide 6.6 natural+ ~1% carbon black
Material (Natural)	Polyamide 6.6 natural
Flammability Rating	UL 94 - V2
Humidity Absorption	2.7% - 2.8% (23°C - 50% R.H.)
Installation Temperature	-20°C to 85°C
Working Temperature	-60°C to 85°C
Max Sustainable Temperature Short Term	110°C
Good Resistance	Bases, Oils, Grease, Oil Derivatives, Chloride Solvents
Limited Resistance	Acid
No Resistance	Phenols
UL Standard	Type 21S

