

16-14 AWG Non-Insulated Butted Ring Connectors Specifications Sheet

OUTLINE DRAWING

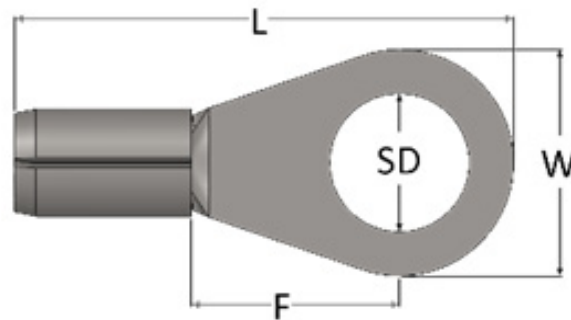

Unit of Measurement: Inches

NOTES

PART #	STUD SIZE	BARREL LENGTH	LENGTH	W	STUD DIAMETER	F
2403	#6	.250	.650	.295	.138/.142	.260
2404	#8	.250	.710	.324	.168/.171	.295
2405	#10	.250	.710	.324	.194/.197	.295
2406	1/4"	.250	.890	.470	.263/.265	.405
2408	5/16"	.250	.890	.470	.324/.327	.405
2409	3/8"	.250	.990	.558	.394/.398	.469

UL/CSA REQUIREMENTS:

- Temperature Rating: 75°C Max. 600V
- One Crimp Required
- Solid or Stranded Wire
- Strip Length 1/4" (6.4 mm)
- Crimp Tool: PICO no. 401/403 Crimp Tool Body with 419 Crimp Die
- 110 Copper Alloy .030 Thickness
- Electro-Tin Plated .0001" - .0003"
- Terminal I.D. - .093

AGENCY & COMPLIANCE:

- UL Listed, investigated to UL 486 A-B
- CSA 22.2 No. 65-03
- RoHS 3 2015/863/EU

WARNING! Incorrect installation of electrical wire and terminals can be hazardous. It can cause an injury or property damage. Refer to National Electrical Code or take advice from the local building inspector for safe wiring practices. To determine the correct wire and terminal size to use and to ensure it will be safely installed, seek guidance from a licensed electrical contractor or engineer.

These are recommendations of procedures by PICO. Use the product after determining it's suitability for the application. PICO is not responsible for any risks and liability for use. Statements related to any PICO products which are not present in PICO of Canada Ltd's recent publications have no validation unless they are authorized by a PICO representative in writing.

