

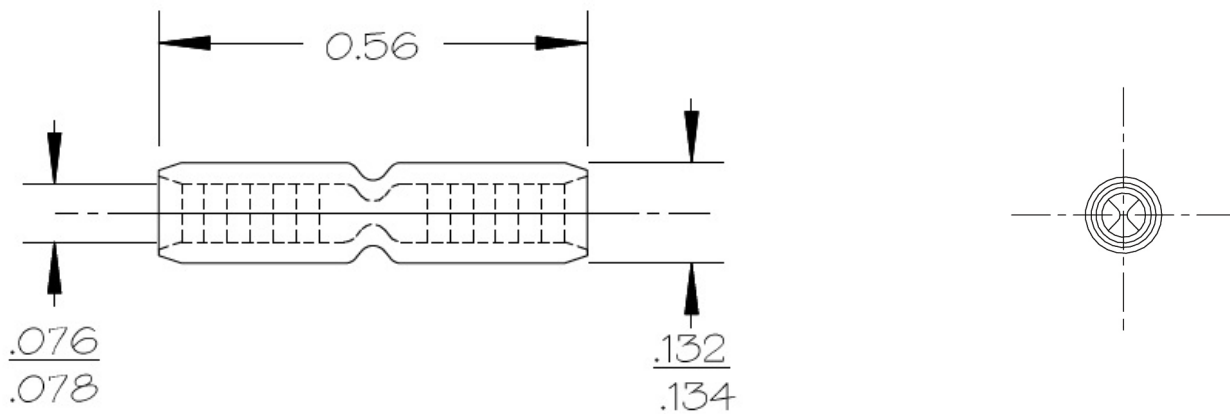

# PICO<sup>®</sup>

## 9100 Specifications Sheet



### Notes

1. Material: Commercial Mild Steel
2. Finish: Nickel Plate
  - ASTM SPEC B-689
  - FED QQ-N-290
  - .0002-.0004 Thick
3. Wire Gauge: 22-18 GA
4. Insulation: Uninsulated
5. Operating Temperature: 900°F (482°C)