

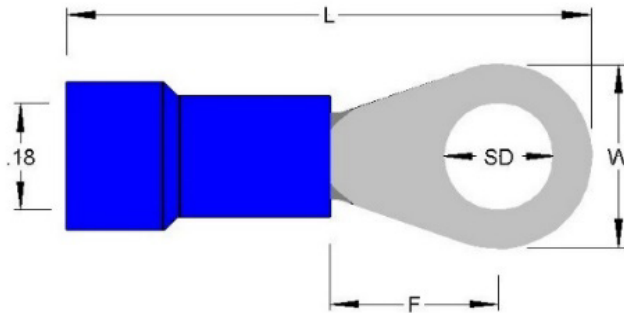

# PICO®

## 5908 Specifications Sheet

### Outline Drawing



Unit of measurement: inches

### Notes

#### UL/ CSA Requirements:

- Temperature Rating: 75°C Max. 600V
- One Crimp Required
- Solid or Stranded Wire
- Strip Length 9/32" (7.1mm)
- Crimp tool: PICO no. 401/403 Crimp Tool handles with 416 Crimp Die
- 110 Copper Alloy .030 thickness,
- Electro-Tin Plated .0001"-.0003"
- Terminal I.D. - .093

#### Agency & Compliance:

- UL listed, investigated to UL 486 A-B
- CSA 22.2 No. 65-03

### Specifications

16-14 AWG

| Part # | Stud Size | Barrel Length | Length | W    | Stud Diameter | F    |
|--------|-----------|---------------|--------|------|---------------|------|
| 5908   | 5/16      | .250          | 1.390  | .470 | .324/.327     | .405 |

**WARNING!** Incorrect installation of electrical wire and terminals can be hazardous. It can cause an injury or property damage. Refer to National Electrical Code or take advise from the local building inspector for safe wiring practices. To determine the correct wire and terminal size to use and to ensure it will be safely installed, seek guidance from a licensed electrical contractor or engineer.

These are recommendations of procedures by PICO. Use the product after determining it's suitability for the application. PICO is not responsible for any risks and liability for use. Statements related to any PICO products which are not present in PICO of Canada Ltd.'s recent publications have no validation unless they are authorized by a PICO representative in writing.

