

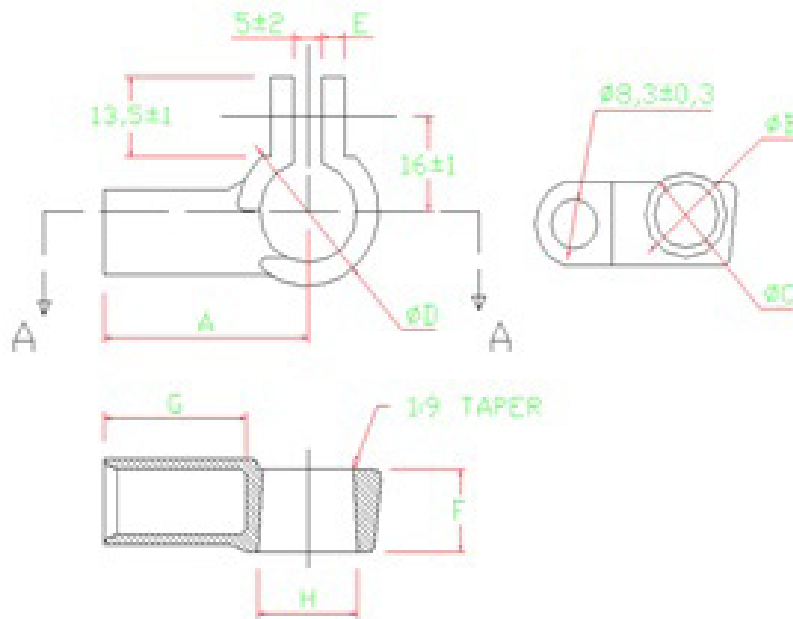

PICO®

5251-5256 Specifications Sheet



Part #	AWG	Polarity	Colour	A	B	C	D	E	F	G	H	Finished Weight
				± 2.00	± 0.50	± 0.50	± 1.00	± 0.50	± 0.50	± 1.00	± 0.50	
5251	2/0	Negative	Orange	36.0	16.0	11.7	25.5	4.5	16.0	25.0	17.7	55.4
5252	2/0	Positive	Orange	36.0	16.0	11.7	26.5	4.5	16.0	25.0	19.4	59.3
5253	3/0	Negative	Purple	36.0	17.9	14.1	25.5	4.5	16.0	25.0	17.7	61.1
5254	3/0	Positive	Purple	36.0	17.9	14.1	26.5	4.5	16.0	25.0	19.4	58.2
5255	4/0	Negative	Yellow	36.0	19.5	16.1	25.5	4.5	16.0	25.0	17.7	62.8
5256	4/0	Positive	Yellow	36.0	19.5	16.1	26.5	4.5	16.0	25.0	19.4	56.2

Notes

1. Material: C11000 ETP Copper
2. Standards: SAE J-1811
3. Dimensions: dimensions in the chart are in millimetre
4. Finished Weight in grams, not including nut & bolt
5. Tin Plate Finish: .0002 to .0004" thickness
6. Bolt Size: .3125-18 x 1.5" Tin Plated with square head and shoulder nut
7. Post Hole Taper: 1:9