

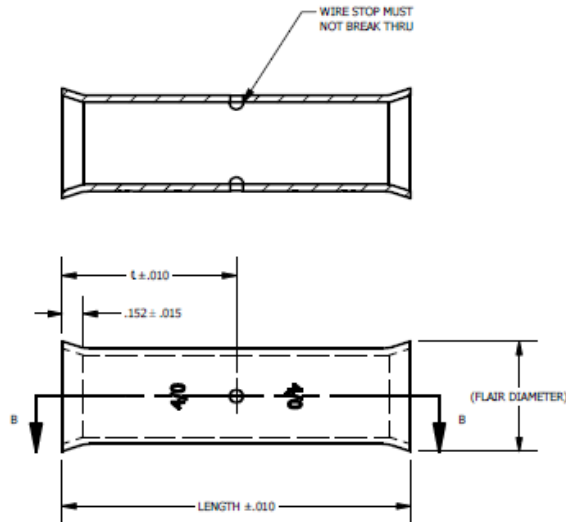

PICO®

4100, 4200, 4300, 4400, 4500, 4600, 4700 Specifications Sheet

Outline Drawing



Mounting

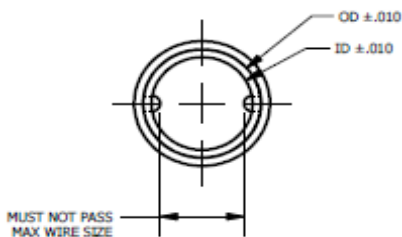

Notes

- Dimensions are in Inches
- Material: Copper CDA-110
- Plating : Electro Tin .0002" - .0003"
- Tolerances Unless otherwise specified:

2 PL. DEC. $\pm .030$

True C.L. $\pm .015$

3PL. DEC. $\pm .015$

Angles ± 1

Specifications

Part Number	Wire Gauge	OD	ID	Length	Flair Diameter
4100	6	0.35	0.237	1.027	N/A
4200	4	0.35	0.283	1.226	0.421
4300	2	0.43	0.33	1.375	0.535
4400	1/0	0.5	0.399	1.562	0.562
4500	2/0	0.562	0.458	1.875	0.625
4600	3/0	0.61	0.51	1.9	0.718
4700	4/0	0.686	0.582	2.5	0.791