

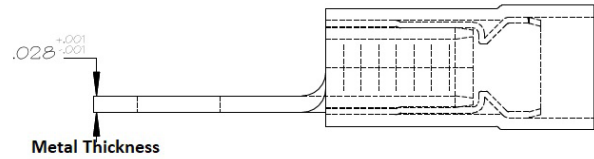

PICO®

2903, 2904, 2905, 2906, 2908 Specifications Sheet

Outline Drawing

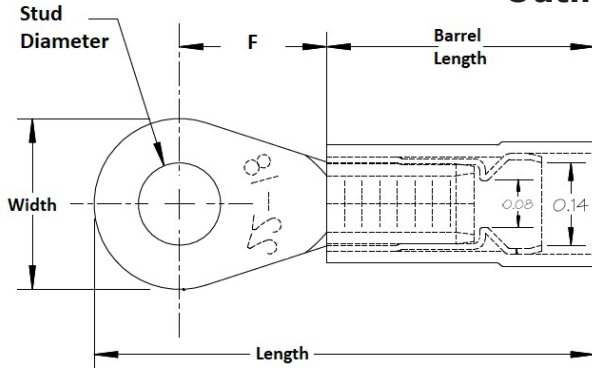

Unit of measurement: inches

Notes

- Material: ETP Alloy 110 Copper 1/2 Hard Temper ASTM Spec B152
- Sleeve Material: Brass .010 Thick, Tin Plated Finish
- Insulator Material: Nylon Type 6/6, Colour: Red, Wall Stock: .020
- Finish: Flash Electro Tin Plate, ASTM Spec B545, Mil Spec: MIL-T-10727C Type 1 .0001-0.00025 Thick
- Temperature Rating: 105°C Max. 600V
- One Crimp Required
- Solid or Stranded Wire
- Strip Length 9/32" (7.1mm)
- Crimp tool: PICO no. 401/403 Crimp Tool handles with 415 or 417 Crimp Die

Specifications

22-18 AWG

Part #	Stud Size	Barrel Length	Length	W	Stud Diameter	F
2903	6	.480	.850	.290	.142/.138	.260
2904	8	.480	.870	.324	.168/.171	.250
2905	10	.480	.870	.324	.194/.197	.250
2906	1/4	.480	1.10	.470	.263/.265	.405
2908	5/16	.250	1.09	.470	.324/.327	.405

WARNING! Incorrect installation of electrical wire and terminals can be hazardous. It can cause an injury or property damage. Refer to National Electrical Code or take advise from the local building inspector for safe wiring practices. To determine the correct wire and terminal size to use and to ensure it will be safely installed, seek guidance from a licensed electrical contractor or engineer.

These are recommendations of procedures by PICO. Use the product after determining it's suitability for the application. PICO is not responsible for any risks and liability for use. Statements related to any PICO products which are not present in PICO of Canada Ltd.'s recent publications have no validation unless they are authorized by a PICO representative in writing.

