

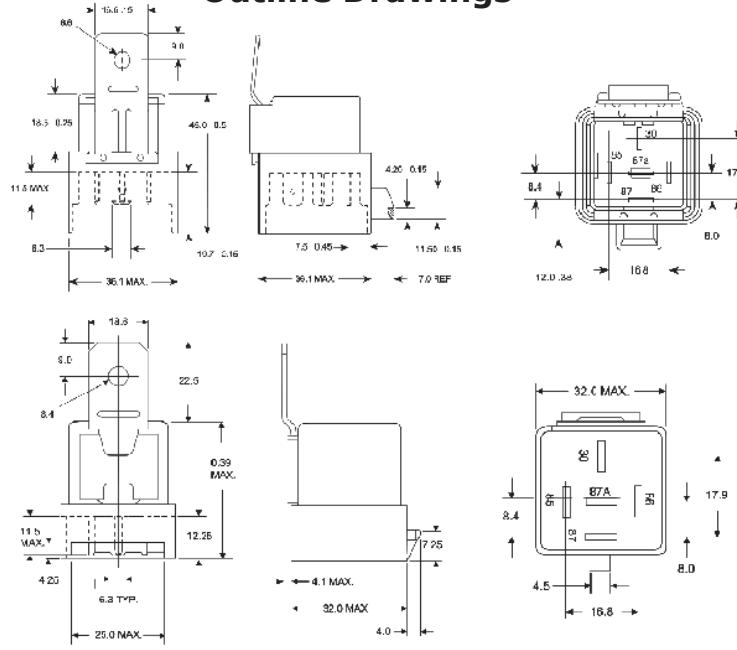

PICO®

927 Specifications Sheet

Outline Drawings



Wiring Diagram

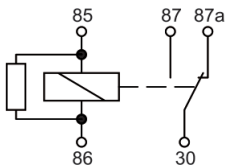

Contact Data

- 1) The values apply to a resistive or inductive load with suitable spark suppression and at maximum 14VDC for 12VDC or 28VDC for 24VDC load voltages. For a load current duration of maximum 3s for a make/break ratio of 1:10.
 - 2) Current and time are compatible with circuit protection by a typical automotive fuse. Relay will make, carry and break the specified current.
 - 3) For unsuppressed relay coil. A low resistive suppression device in parallel to the relay coil increases the release time and reduces the lifetime caused by increased erosion and/or higher risk of contact tack welding.
 - 4) Without Components in Parallel.
- All figures are given for coil without pre-energization, at ambient temperature +23°C.

Contact Arrangement	1 form C, 1 CO
Rated Voltage	12VDC
Limiting Current	
Form A/Form B	NO/NC
23°C	60/45A
85°C	40/30C
125°C	17/12A
Limiting Making Current⁽¹⁾	120/45A
Form A/Form B	
Limiting Breaking Current	60/40A
Form A/ Form B	
Limiting Short-Term Current	1.35 x 40A, 1800s
Overload Current	2.00 x 40A, 60s 6.00 x 40A, 1s
Jump Start Test	24VDC for 5min, Conducting Nominal Current at 23°C
Contact Material	Silver Based
Min. Recommended Contact Load	1A at 5VDC
Initial Voltage Drop	
Form A (NO) contact at 40A, typ./max.	60/200mV
Form B (NC) contact at 30A, typ./max.	60/250mV
Frequency of Operation at Nominal Load	6 ops./min (0.1Hz)
Operate/Release Time typ.	7/2ms ⁽³⁾
Electrical Endurance	>1x10 ⁵ ops.
Resistive Load, Form A (NO) Contact	40A, 14VDC
Resistive Load, Form B (NC) Contact	30A 14VDC
Mechanical Endurance	>1x10 ⁶ ops.

Coil Data

Rated Coil Voltage 12/24VDC

Coil Versions, DC Coil

Coil Code	Rated Voltage VDC	Operate Voltage VDC	Release Voltage VDC	Coil Resistance ⁽⁴⁾ Ω±10%	Rated Coil Power ⁽⁴⁾
F	12	7.2	1.2	90	1.6
H	24	14.4	2.4	360	1.6

Insulation Data

Initial Dielectric Strength	500Vrms
Between Open Contacts	500Vrms
Between Contact and Coil	500Vrms
Between Adjacent Contacts	500Vrms